



IC CORPORATION STANDARD SPECIFICATIONS

GAW Rating (lbs.)

	STD.	MAX.
Front	8,000	10,000
Rear	17,500	21,000

GVW Rating (lbs.)

Total	25,500	31,000
-------	--------	--------

NOTE: Model Code and Wheelbase Must Be Specified on Order.

CE School Bus

**Model Code:
IC3S530**

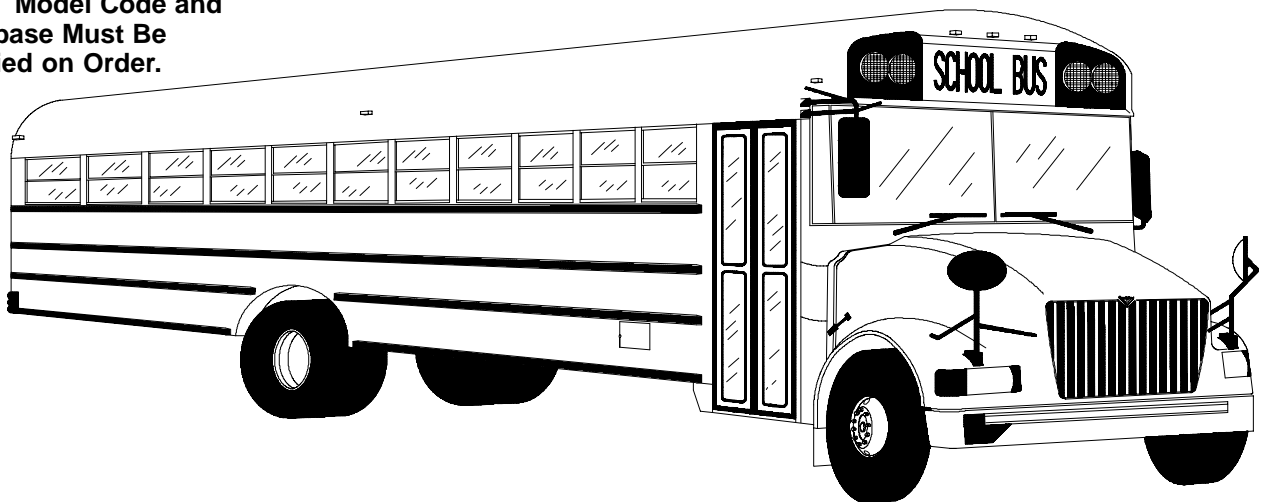

Refer to Chart Pages for Weight, Turning Radius and Dimension Information.

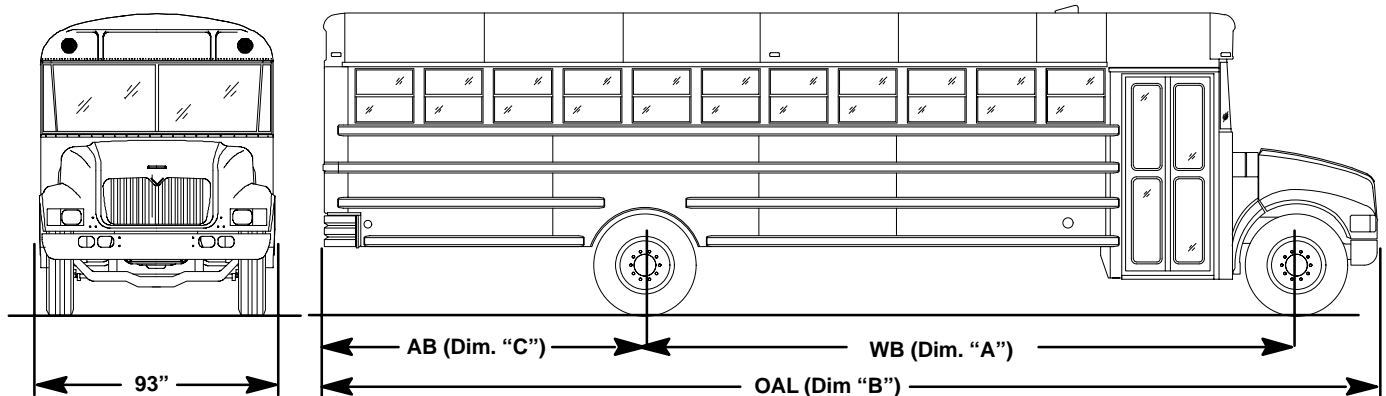



IC CORPORATION STANDARD SPECIFICATIONS

GAW Rating (lbs.)

STD. MAX.

Front 8,000 10,000

Rear 17,500 21,000

GVW Rating (lbs.)

Total 25,500 31,000

CE Commercial Bus

Model Code:
IC3C530

NOTE: Model Code and Wheelbase Must Be Specified on Order.



Refer to Chart Pages for Weight, Turning Radius and Dimension Information.

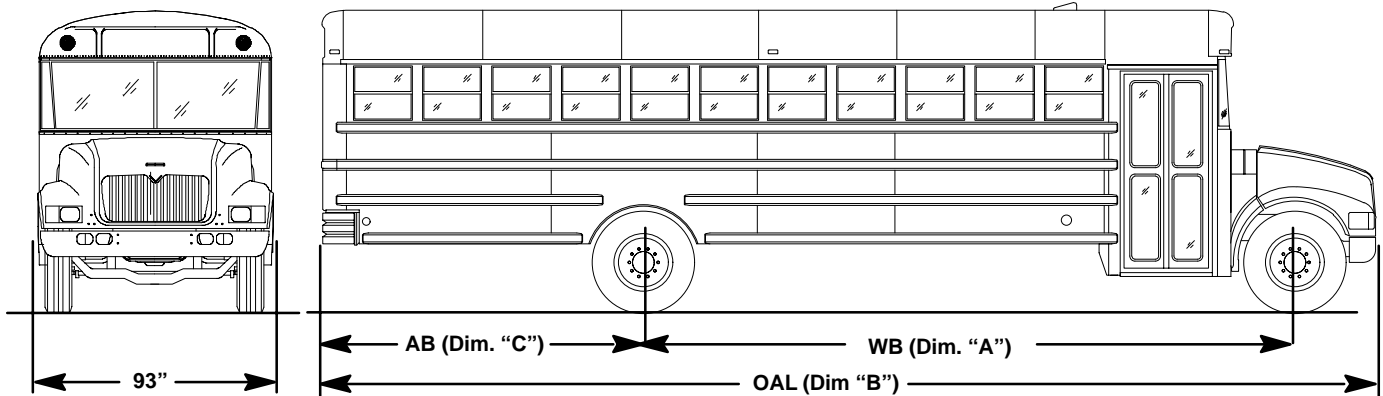



DIMENSIONS

Body Length	Body Code	Wheelbase Dim "A" @	Overall Vehicle Length Dim. "B" * @	Axle to Bumper Dim. "C" * @
16' 2"	47ACH, 47ADX	152	251.3	66.5
16' 11"	47ACJ, 47ACK, 47ADY, 47ADZ	152	260.3	75.5
17' 8"	47ACL, 47AEA	152	269.3	84.5
18' 5"	47AGP, 47AGR	152	278.3	93.5
19' 2"	47BBJ, 47BBL, 47BBK, 47BBM	152	287.3	102.5
18' 5"	47ACM, 47AEB	170	278.3	75.5
19' 2"	47ACP, 47ACR, 47AED, 47AEE	170	287.3	84.5
19' 2"	47ACP, 47ACR, 47AED, 47AEE	170	287.3	84.5
19' 11"	47ACN, 47AEC	170	296.3	93.5
20' 8"	47ACS, 47AEG	193	305.3	79.5
21' 5"	47ACT, 47ACU, 47AEH, 47AEJ	193	314.3	88.5
22' 2"	47ACV, 47AEK	193	323.3	97.5
22' 11"	47ACW, 47AEL	193	332.3	106.5
23' 8"	47ACX, 47ACY, 47AEM, 47AEN	193	341.3	115.5
24' 5"	47ACZ, 47AEP	218	350.3	99.5
25' 2"	47ADA, 47AER	218	359.3	108.5
25' 11"	47ADB, 47ADC, 47AES, 47AET	218	368.3	117.5
26' 8"	47ADE, 47AEU	218	377.3	126.5
27' 5"	47ADG, 47AEV	236	386.3	117.5
28' 2"	47ADJ, 47ADK, 47AEX, 47AEY	236	395.3	126.5
28' 11"	47ADH, 47AEW	236	404.3	135.5
29' 8"	47ADL, 47AEZ	254	413.3	126.5
30' 5"	47ADM, 47ADN, 47AGA, 47AGB	254	422.3	135.5
31' 2"	47ADP, 47AGC	254	431.3	144.5
31' 11"	47ADR, 47AGD	254	440.3	153.5
31' 11"	47ADS, 47AGE	276	440.3	131.5
32' 8"	47ADT, 47ADU, 47AGG, 47AGH	276	449.3	140.5
33' 5"	47ADV, 47AGJ	276	458.3	149.5
34' 2"	47ADW, 47AGK	276	467.3	158.5

NOTE:Dimensions "B" and "C" include a 1" rear bumper extension.

NOTE:Based on International Chassis Usage